

B

A

A

A

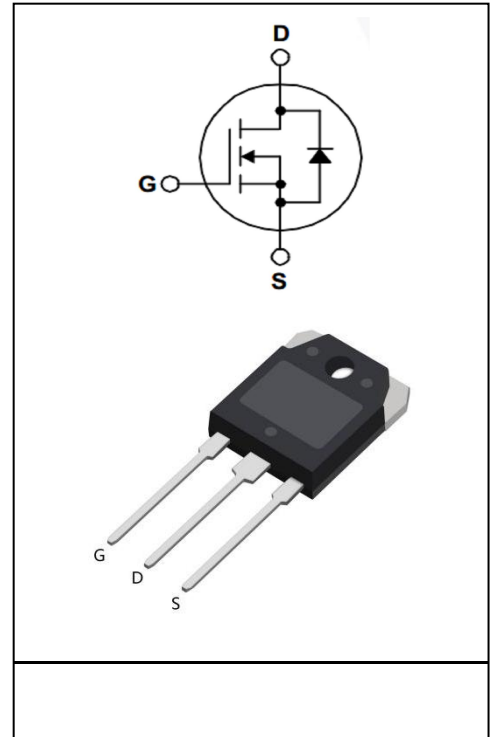

	A

-
-
-
-
-
-

-
-
- A

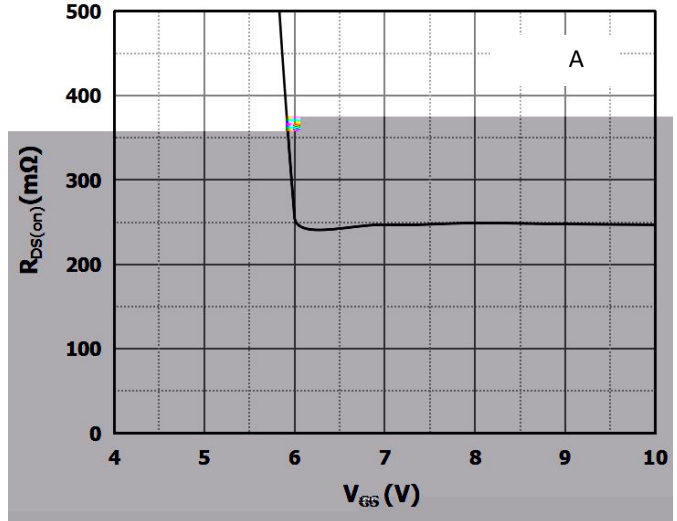
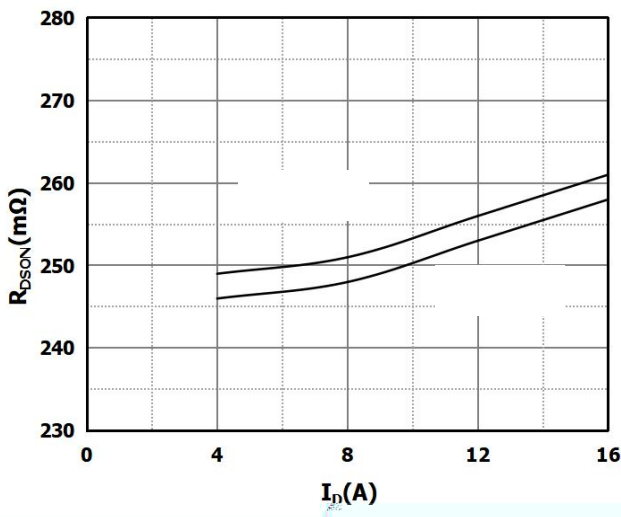
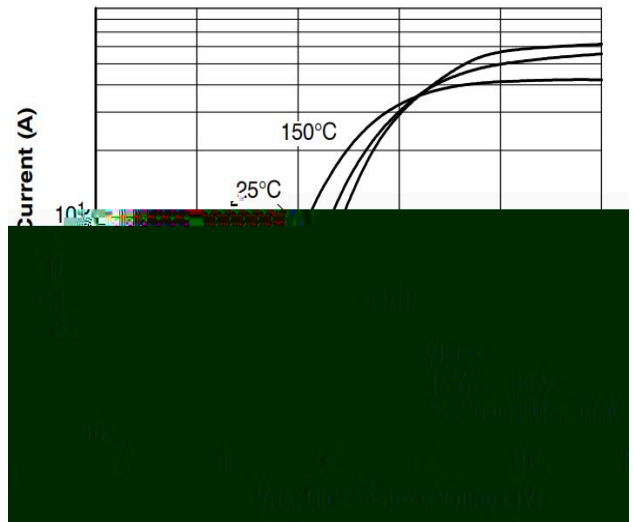
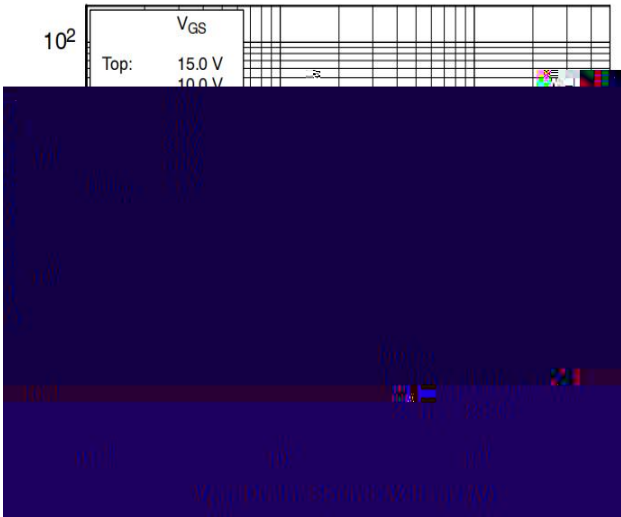

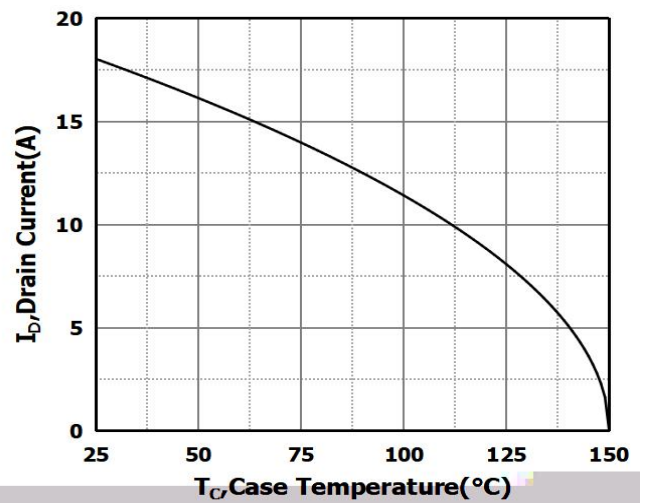
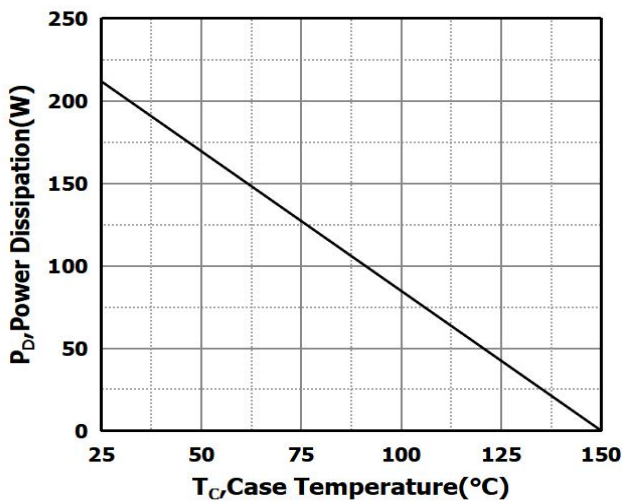
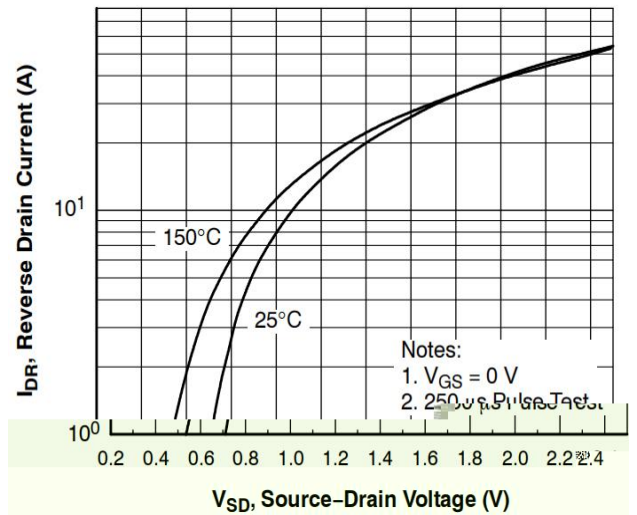
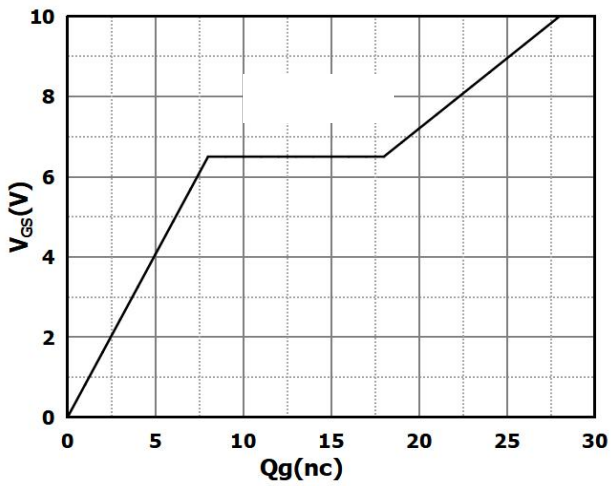
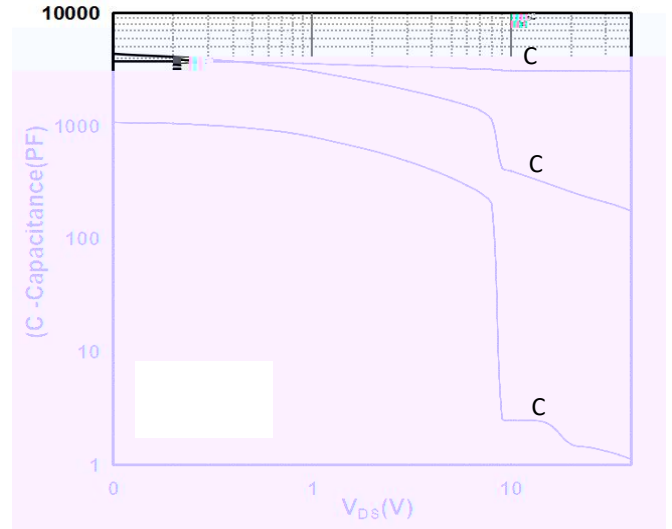
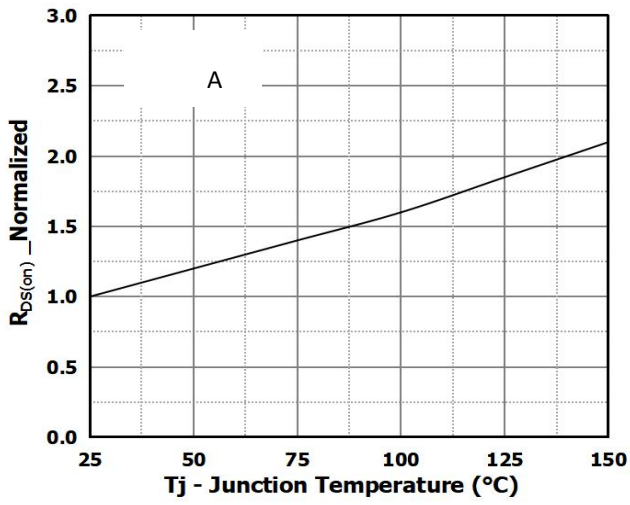

Test Circuit & Waveform

Gate Charge Test Circuit & Waveform

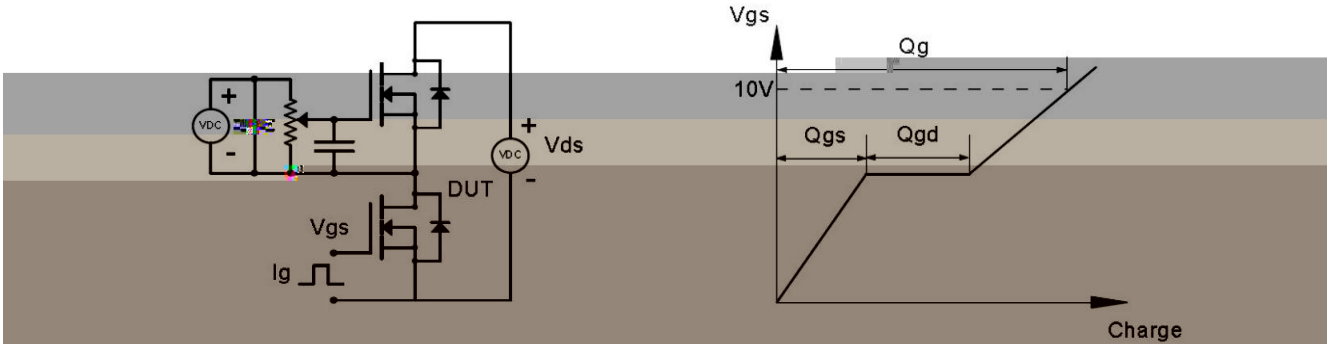

Resistive Switching Test Circuit & Waveforms

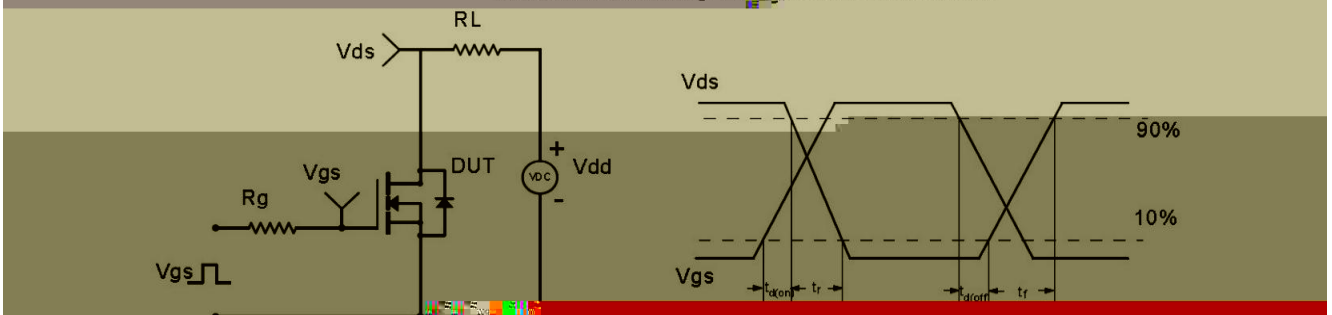

基本尺寸

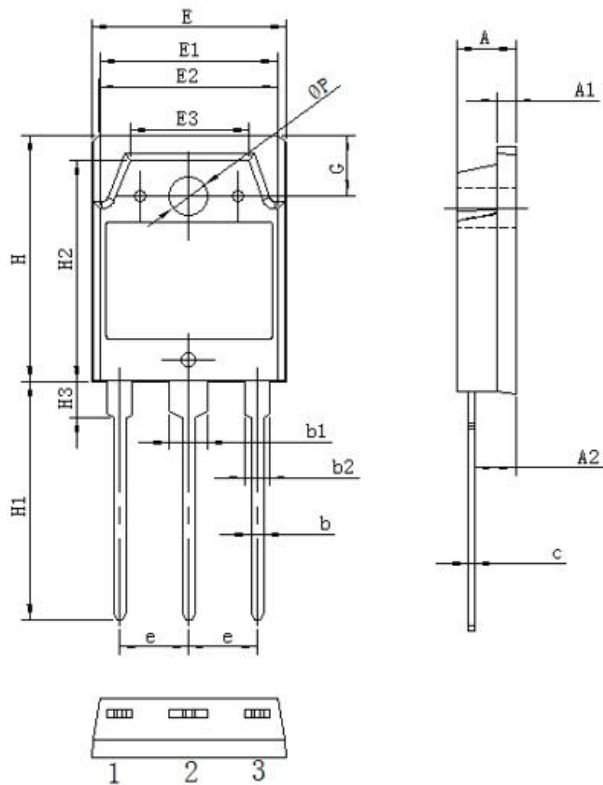

Symbol	单位 mm		
	Min	Nom	Max
A	4.60	4.80	5.00
A1	1.3	1.5	1.7
A2	2.20	2.40	2.60
b	0.80	1.0	1.20
b1	2.90	3.10	3.30
b2	1.90	2.10	2.30
c	0.50	0.60	0.70
e	5.25	5.45	5.65
E	15.2	15.6	16.0
E1	13.2	13.4	13.6
E2	13.1	13.3	13.5
E3	9.1	9.3	9.5
H	19.8	20.0	20.2
H1	19.4	19.8	20.2
H2	18.5	18.7	18.9
H3	2.9	3.1	3.3
G	4.8	5.0	5.2
ΦP	3.00	3.20	3.40